

Electric Actuator
Installation, Operation &
Maintenance Manual

INTRODUCTION:

Thank you for selecting Elite Valve Canada for your valve or damper automation requirement. We at Elite Valve Canada are proud of our products and feel confident they will meet or exceed your expectations of quality and reliability.

Every precaution has been taken to insure that your equipment will arrive undamaged; however, accidents do occur. Therefore, the first thing you must do upon receipt of your package is to inspect it for damage. If the box is damaged there is a possibility that the equipment inside the box may be damaged as well. If this is the case **YOU MUST FILE A CLAIM** with the delivering **CARRIER**. All shipments are **F.O.B.** our factory and it is **YOUR RESPONSIBILITY** to file a claim for damages.

STORAGE:

If the actuators are scheduled for installation at a latter date:

1. Store off the floor.
2. Store in a climate controlled building.
3. Store in a clean and dry area.

FOR FUTURE REFERENCE RECORD:

1. Actuator model number _____
2. Actuator enclosure type NEMA 4____, NEMA 4X____, NEMA 7____, NEMA 4 & 7_____
3. Actuator output torque _____ LB-IN
4. Motor characteristics, Voltage _____ Hertz _____ Phase _____
5. Actuator serial number _____
6. Date of installation _____ Put into operation _____
7. Valve Data:
 - 7a. Manufacturer _____
 - 7b. Style & fig. No. _____
 - 7c. Size _____
 - 7d. End connection _____
 - 7e. Material of construction, Body _____ Stem & ball _____
 - 7f. Brake away torque _____ LB-IN @ _____ PSI
 - 7g. Other helpful data _____

MEDIA:

1. System media _____
2. Temperature, _____ deg. F. Maximum, _____ deg. F. Minimum _____
3. Pressure _____ PSI

As this information is listed it is important to pay attention to all of the actuator specifications relative to the valve specifications and system requirements. If the actuator is not properly sized for the valve and application the life will be shortened or it may not work at all.

TOOLS REQUIRED:

100 In-Lb SERIES

Cover screws	9/64" Allen wrench.
Terminal strip screws	1/8" wide flat head screw driver.
Cam setscrew	5/64" Allen wrench.
Mounting pad screws	3/8" socket.

200 & 300 In-lb SERIES

Cover screws	SD, Phillips head screwdriver, Deep Base, 9/64 Allen wrench, NEMA 7 enclosure, 7/16" socket.
Position indicator	5/64" Allen wrench.
Terminal strip screws	1/8" wide flat head screw driver.
Cam setscrew	5/64" Allen wrench.
Mounting pad screws	3/8" socket.

400, 675, 1000, & 1500 In-Lb SERIES

Cover screws	5/32" Allen wrench, NEMA 7 enclosure, 7/16" socket.
Terminal strip screws	3/16" wide flat head screw driver.
Cam setscrew	5/64" Allen wrench.
Mounting pad screws	1/2" socket.

2000 & 3840 In-Lb SERIES

Cover screws	7/16" socket.
Terminal strip screws	3/16" wide flat head screw driver.
Cam setscrew	5/64" Allen wrench.
Mounting pad screws	9/16" socket.

5000, 7020, 11520, 14040, & 27300 In-Lb SERIES

Cover screws	1/2" socket.
Position indicator	5/64" Allen wrench.
Terminal strip screws	3/16" wide flat head screw driver.
Cam setscrew	5/64" Allen wrench.
Mounting pad screws	3/4" socket.

Additional tools will be required for the screws to mount the valve to the actuator.

SUGGESTED MAXIMUM TORQUE VALUES FOR FASTENERS in In-Lb

Screw Size	Low Carbon Steel	18-8 SS	316 SS	Aluminum
2-56	2.2	2.5	2.6	1.4
4-40	4.7	5.2	5.5	2.9
6-32	9	10	10	5
8-32	18	20	21	10
10-24	21	23	24	13
10.32	30	32	33	19
1/4-20	65	75	79	45
5/16-18	129	132	138	80

3/8-16	212	236	247	143
1/2-13	465	517	542	313
5/8-11	1000	1110	1160	715

INSTALLATION:

The actuator is shipped in the open position from the factory, it is important to make sure the valve and actuator are in the same position before mounting the actuator on the valve.

1. Manually open valve.
2. Remove valve mechanical stops. **CAUTION: DO NOT REMOVE** any parts necessary for the proper operation of the valve, i.e., packing gland, gland nut, etc.
3. Check again that the valve and actuator are in the same position.
4. Install mounting hardware on valve, do not tighten bolts securely at this time, mount actuator to valve, once actuator screws have been started securely tighten all nuts and bolts. **NOTE:** Actuator conduit entry is normally positioned perpendicular to pipe line.
5. Remove actuator cover.
6. Wire actuator using the wiring diagram inside cover. **CAUTION:** Be sure power is off at the main power box.
7. Turn on power to actuator. **CAUTION:** Use extreme caution, as there are live circuits that could cause electrical shock or death.
8. Operate the valve to the close position, check the alignment.
9. Operate the valve to the open position, check the alignment.
10. Replace cover and secure cover screws.

CALIBRATION:

After checking the alignment of the valve port calibration may be required.

To set the open position:

1. Operate valve to the open position by applying power to terminal connections #1 and #2, the valve will rotate counter clockwise, CCW, viewing top of actuator. **NOTE:** When the actuator is in the open position the setscrew securing the cam to the shaft will be easily accessible.
 - 1a. If valve did not open completely;
 - 1aa. Loosen 8-32 set screw in top cam.
 - 2aa. Rotate cam clockwise (CW) until the switch makes contact, listen carefully for a slight click. The valve will begin to rotate CCW, by making small incremental CW movements of the cam the valve can be positioned precisely in the desired position.
 - 3aa. Securely tighten the setscrew.
 - 1b. If valve traveled too far. **CAUTION:** Valves with mechanical stops may be damaged or cause damage to the actuator if allowed to travel too far.
 - 1bb. Apply power to terminal connections #1 and #3, the valve will begin to rotate CW, allow it to travel to the mid position.
 - 2bb. Follow directions in 1a of "To set open position".

To set close position:

1. Operate valve to the close position by applying power to terminal connections #1 and #3, the valve will rotate CW viewing the top of the actuator. **NOTE:** When the actuator is in the close position the setscrew securing the close cam to the shaft will be easily accessible.

- 1a. If valve did not close completely;
 - 1aa. Loosen 8-32 set screw in bottom cam.
 - 2aa. Rotate cam CCW until the switch makes contact, listen for a slight click. The valve will begin to rotate CW, by making small CCW incremental movements of the cam the valve can be positioned precisely in the close position.
 - 3aa. Securely tighten the setscrew.

To set close position, continued:

- 1b. If the valve has traveled too far closed. **CAUTION:** Valves with mechanical stops may be damaged or cause damage to the actuator if allowed to travel too far closed.
 - 1bb. Apply power to terminal connection #1 and #2, the valve will begin to rotate CCW, allow to rotate to the mid position.
 - 2bb. Follow directions in 1a. of “To set close position”.

WIRING DIAGRAM TWO POSITION ACTUATOR

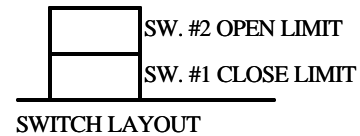
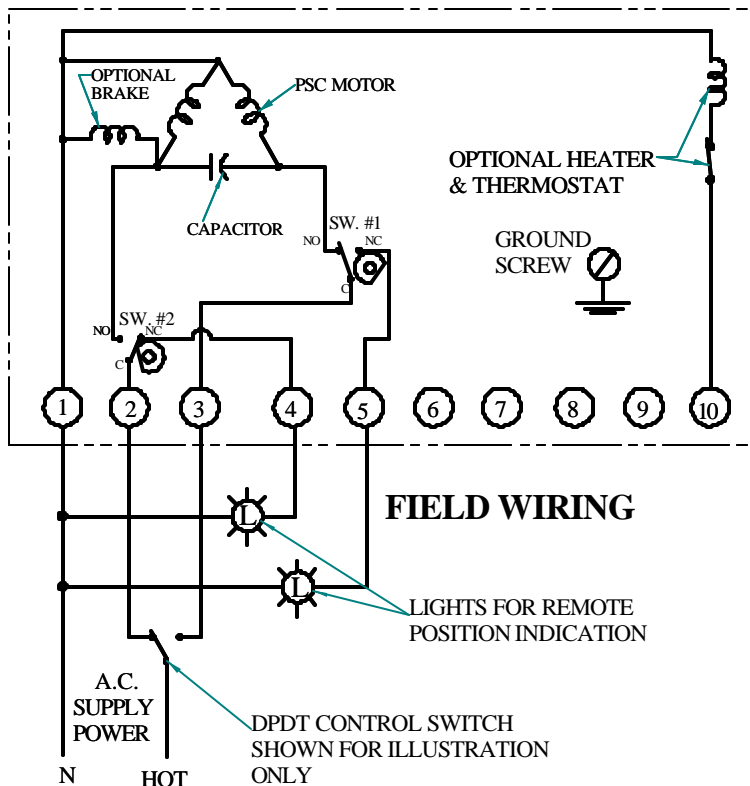

NOTES:
 POWER TO TERMINALS ONE & TWO OPENS THE VALVE (CCW ROTATION)
 POWER TO TERMINALS ONE & THREE CLOSES THE VALVE (CW ROTATION)
 TERMINALS 4 & 5 ARE FOR LIGHT INDICATION
 WIRING DIAGRAM ILLUSTRATES THE ACTUATOR IN THE OPEN POSITION

WIRING DIAGRAM FOR STANDARD 1PH/60Hz/AC ELECTRIC ACTUATOR ILLUSTRATING OPTIONAL HEATER, THERMOSTAT & BRAKE.

DWG. #990520

WIRING DIAGRAM ACTUATOR WITH 4-20mA CONTROL

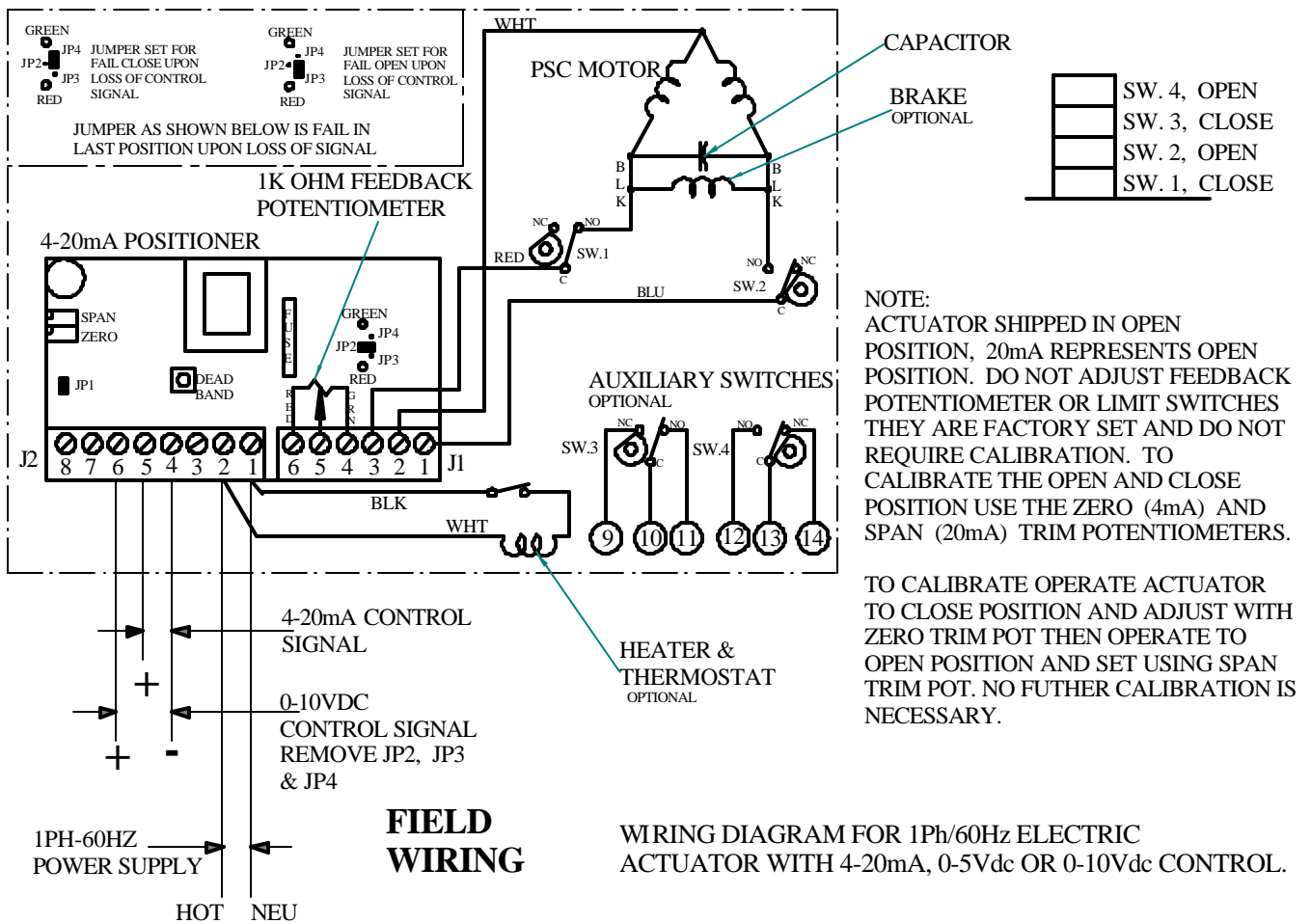

ACTUATORS WITH TORQUE SENSORS (5000, 7020, 11500, 14040, & 27300 In-Lb SERIES)

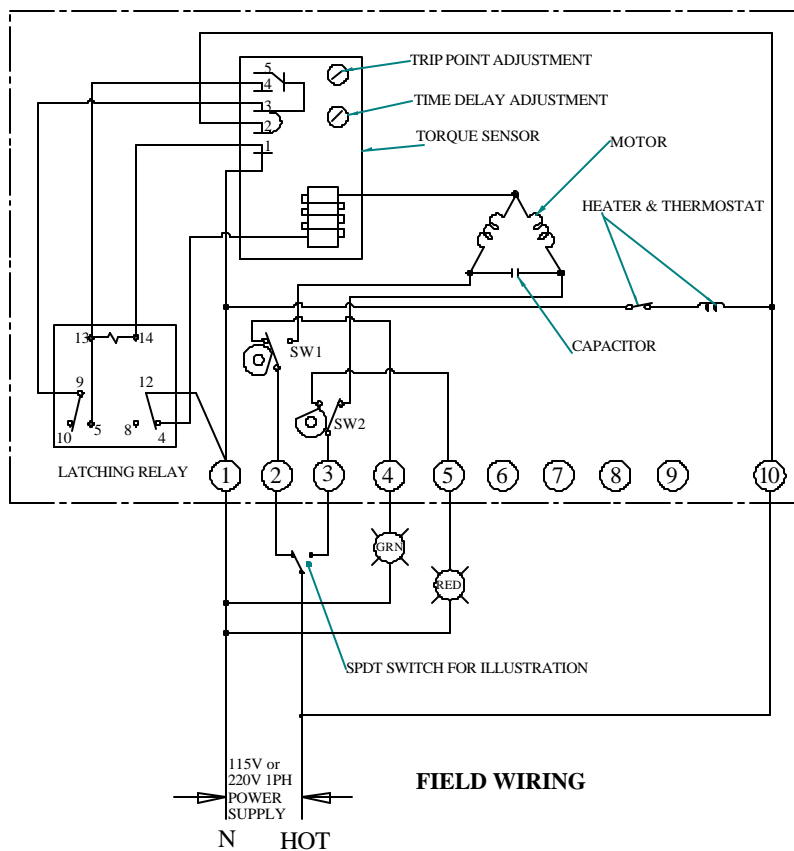

OPERATION:
ACTUATOR IS SHOWN IN THE OPEN POSITION.

TRIP POINT IS SET AT ACTUATORS RATED TORQUE. TIME DELAY IS SET TO AVOID TRIP DUE TO INRUSH CURRENT.

POWER TO TERMINALS #1 & #2 FOR CCW ROTATION.
POWER TO TERMINALS #1 & #3 FOR CW ROTATION.

UNDER NORMAL OPERATION THE TORQUE SENSOR HAS NO AFFECT ON THE OPERATION OF THE ACTUATOR. HOWEVER, SHOULD THE ACTUATOR BECOME STALLED FOR ANY REASON WHAT SO EVER THE MOTOR CURRENT EXCEEDS THE TRIP POINT SETTING AND THE TORQUE SENSOR ACTIVATES THE LATCHING RELAY DISCONNECTING THE MOTOR FROM THE POWER SUPPLY. THE UNIT WILL NOT START AGAIN UNTIL THE POWER IS SHUT OFF AND REAPPLIED OR THE ACTUATOR IS GIVEN A SIGNAL TO ROTATE IN THE REVERSE DIRECTION. THE ACTUATOR WILL NOT COMPLETE ITS CYCLE UNTIL THE CAUSE FOR EXCESSIVE CURRENT IS TAKEN CARE OF.

HEATER AND THERMOSTAT ARE OPTIONAL.

**WIRING DIAGRAM FOR
ACTUATORS WITH TORQUE SENSOR
AND 4-20mA control**

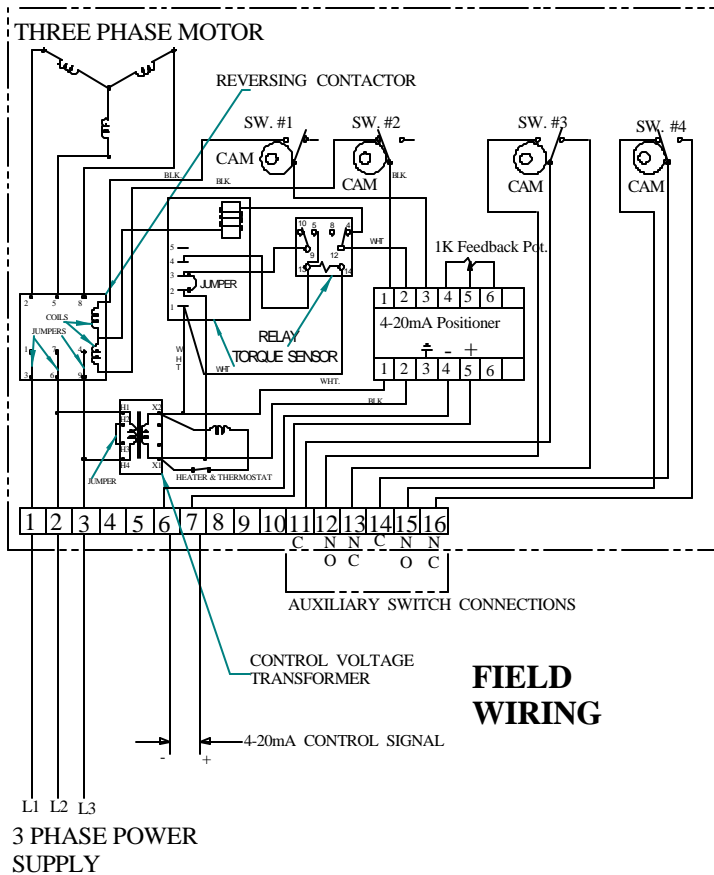

SW. #4	OPEN POSITION AUXILIARY SWITCH
SW. #3	CLOSE POSITION AUXILIARY SWITCH
SW. #2	OPEN LIMIT SWITCH
SW. #1	CLOSE LIMIT SWITCH

SWITCH LAYOUT
AUXILIARY SWITCHES ARE OPTIONAL

MAINTENANCE:

After your Elite Valve Canada electric actuator has been properly installed, there is little or no maintenance ever required. The gear train has been permanently lubricated at the factory and requires no routine maintenance. In the event it becomes necessary to perform maintenance on the actuator upon reassembling, we recommend using Lubriplate EMB grease.

INSTALL & SET AUXILIARY SWITCHES:

Tools Required:

Cover Removal	Phillips head screwdriver
Terminal Screws	1/8" wide screwdriver
Cam Adjustment	5/64" Allen wrench
Cut Wires	Wire cutters

Note:

Read these instructions completely before beginning installation, if you have any questions please contact us at **519-332-8809** for assistance.

Procedure:

1. Turn off power supply to actuator.
2. Remove four (4) screws securing cover to gearbox, remove cover.
3. Remove two (2) 4-40 x 1" long screws securing switches to base.
4. Stack auxiliary switch (es) on top of existing limit switches.
5. Secure switches with 4-40 x 1 1/2" long screw if one auxiliary switch was added or 4-40 x 2" long screw if two auxiliary switches were added.
6. Install cam.
7. Using wire cutter snip the yellow and orange wires on limit switches and remove.
8. Connect the common (C) lead of third switch to terminal connection #4, the normally open (NO) to #5 and normally closed (NC) to #6. If a second auxiliary switch is being installed connect common (C) of top switch (#4 up from base) to terminal connection #7, the NO to #8 and NC to #9.

Set Auxiliary Switch:

1. Turn on power to actuator. **CAUTION: At this time there are live circuits in the actuator; contact may cause electrical shock or death.**
2. Operate actuator to the close position.
3. Rotate the third cam up from the base CCW so the setscrew is accessible and the round of the cam has switch arm compressed.
4. Rotate the cam CW until you hear the switch snap from the NO to the NC contact.
5. Lock cam in position by securing 8-32 x 1/4" long set screw to shaft.
6. Operate actuator to the open position.
7. Rotate top cam CW so set screw is accessible and round of cam has switch arm compressed.
8. Rotate top cam CCW until the switch snaps from the NO to the NC contact.
9. Lock cam in position by securing 8-32 x 1/4" long set screw to shaft.
10. Wire auxiliary switch to peripheral equipment, use terminal connections 4 through 9.
11. Test setting to assure proper operation.
12. If desired setting has not been achieved repeat steps 2 through 11.
13. Once proper settings have been accomplished replace cover and secure cover screws.

INSTALL & SET POWER OFF BRAKE:

TOOLS REQUIRED:

5/32" Allen wrench, 3/16" wide flat screw driver, 0.050 Allen wrench.
Phillips head screw driver (cover removal, SD series).

Read instructions before beginning installation, see FIG. 1 for illustration, if you have any questions please call Elite Valve Canada 519-332-8809.

1. Turn off supply power to actuator.
2. Remove cover screws.
3. Remove cover.
4. Loosen and remove four screws (two screws on 2000 lb-in torque and higher) securing motor to gearbox.
5. Install motor brake/mounting bracket on top of the motor and replace the four screws removed in step 4 with four 6-32x2" screws supplied with kit.

6. Align the hole in the center of the brake with the OD of the 3/16" motor shaft extending through the top of the motor.
7. Tighten the four motor screws securely.
8. Slide the brake armature hub (round aluminum part with square drive on one end) onto the 3/16" dia. motor shaft and in to square opening in brake friction disc. **NOTICE:** Brake armature hub must engage brake friction disc.
9. Using .050 Allen wrench secure setscrew in brake armature hub to motor shaft.
10. Loosen and remove the blue wire nut on both sides of the motor capacitor. Connect the white brake wire to side of the capacitor with the red motor wire and replace the blue wire nut. Connect the black brake wire to the side of the capacitor with the brown motor wire and replace the blue wire nut.

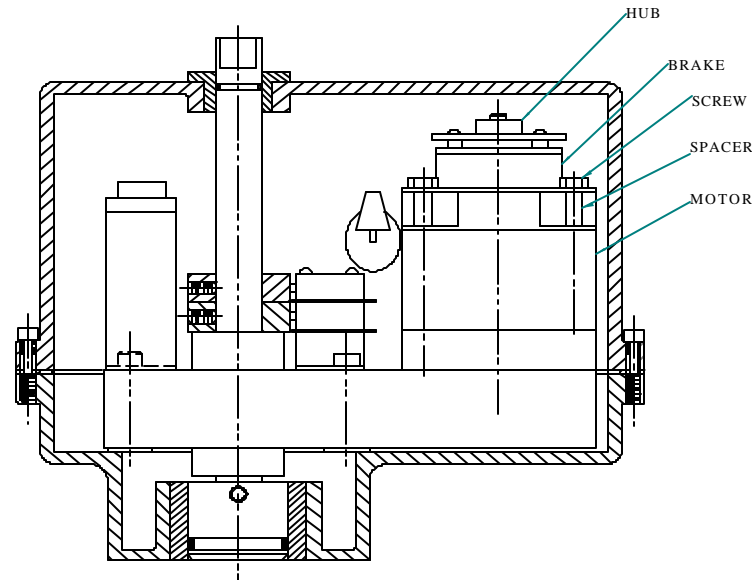

FIG. 1

TO TEST:

CAUTION: It will be necessary to turn the supply power on to test the actuator, use caution when testing the actuator to prevent electrical shock.

11. Apply power to terminals #1 and #2, actuator should rotate to the open position.
12. Apply power to terminals #1 and #3, actuator should rotate to the close position.
13. If assistance is required in performing these instructions please call your Elite Valve Canada distributor or call Elite Valve Canada directly at 519-332-8809.
14. Replace cover and cover gasket.
15. Secure cover screws.

NOTE: Actuators produced after 2000 do not require spacer.

DUTY CYCLE:

Elite Valve Canada actuators rated 100 LB-IN up to 1500 LB-IN output torque are rated for 25% duty cycle at 100% ambient temperature at rated torque (75% duty cycle motors are available upon request). Actuators rated for 2000 LB-IN output torque and greater are rated for continuous duty. All direct current (dc) motors are rated for 75% duty cycle.

THERMAL OVER LOAD:

All alternating current (ac) motors are equipped with thermal over load protection to guard the motor against damage from over heating.

MECHANICAL OVER LOAD:

Elite Valve Canada actuators are all designed to withstand stall conditions. It is not recommended to subject the unit to repeated stall conditions; however, should it occur the actuator would not experience gear damage.

ORDERING PARTS:

When ordering parts please specify:

Actuator model number, actuator serial number, part number and part description.

RECOMMENDED SPARE PARTS:

Two Position Actuators:

Set of cams and switches.

Modulating Actuators:

Set of cams, switches, feedback potentiometer and a positioner card.

NEMA 7 ENCLOSURE, GENERAL:

In general, operation and maintenance of a NEMA 7 electric actuator is no different than that of a NEMA 4 electric actuator. However, there are some precautions that must be followed.

1. **DO NOT** install in ambient temperatures that exceed **140 degrees F**.
2. **DO NOT** under any circumstances **remove the actuator cover** while in a hazardous location when the contacts are still live, this could cause ignition of hazardous atmospheres.
3. **DO NOT** under any circumstances **use a NEMA 7 electric actuator in a hazardous location that does not meet the specifications for which the actuator was designed**. The actuator is clearly tagged with the NEMA classification it was designed for.
4. Mount, test and calibrate actuator on valve in non-hazardous location.
5. When removing the cover care must be taken not to scratch, scar or deform the flame path of the cover or base of the actuator, this will negate the NEMA 7 rating of the enclosure.
6. When replacing the cover on actuators rated NEMA 4 and 7 take care that the gasket is in place to assure the proper clearance after the cover is secured. After securing the cover screws check the clearance between the cover and the base, a .002" thick by 1/2" wide feeler gauge may not enter between the two mating faces more than .125".
7. All electrical connections must be to state and local codes and in accordance with the specifications for which the unit is being used.

After proper installation the actuator will require little or no maintenance, in the event maintenance is required remove it from the hazardous location before attempting to work on it. If the actuator is in a critical application and down time is not permitted it is advisable to have a spare actuator in stock.

WARRANTY:

Elite Valve Canada warrants that for a period of twelve months from the date of shipment it will either repair or replace, at its option, any of its products, which prove to be defective in material or workmanship. This warranty **does not** cover damage resulting from causes such as abuse, misuse, modification or tampering. This warranty is extended only to the immediate purchaser of Elite Valve Canada's product and is not transferable. To obtain service under this warranty, the purchaser must first obtain a return authorization number from Elite Valve Canada. Products must be returned to Elite Valve Canada **freight prepaid** for evaluation. If the unit failed due to poor workmanship or materials the unit will be repaired or replaced. The unit will be returned ground freight paid by Elite Valve Canada. If air shipment is requested, the purchaser shall pay the difference. This warranty is in lieu of all other obligations, liabilities or expressed warranties. Any implied warranties, including any implied warranty of

merchantability are hereby expressly excluded. In no event shall Elite Valve Canada be liable for special, incidental or consequential damages arising in connection with the use of its products, or for any delay in the performance of this warranty due to causes beyond its control.

TROUBLE SHOOTING:

SYMPTOM	PROBLEM	SOLUTION
Actuator does not respond to control signal.	Power not on.	Turn on power.
	Actuator wired wrong .	Check wiring diagram & rewire.
	Wrong voltage .	Check power supply & make appropriate changes.
	Thermal overload activated.	Allow motor to cool, actuator will automatically reset.
	Actuator and valve in opposite positions when actuator was mounted.	Remove actuator and rotate 90 degrees & remount.
	Torque trip point set too low.	Increase trip point
Actuator will not open or close completely.	Torque trip delay set too short.	Increase delay time
	Travel limits set wrong.	Reset cams, see Pgs. 3 & 4.
	Valve torque too high for actuator.	Install correct size actuator.
	Mechanical stops not removed.	Remove stops, CAUTION: Do not remove any part required for proper operation.
	Torque trip point set too low.	Increase trip point
	Torque trip delay set too short	Increase delay time
Valve oscillates.	Valve torque too high for actuator.	Install correct size actuator.
	Actuator without brake installed on butterfly valve.	Install brake see pg. 9 & 10.
	Motor brake out of adjustment.	Adjust brake see pg. 9 & 10.
	Set screw loose in brake disc.	Adjust brake and tighten set-screw see pg. 9 & 10.
Motor runs but output shaft does not rotate.	Gear damage or sheared pin.	Contact Elite Valve Canada or nearest distributor.